

7  
|  
8-31

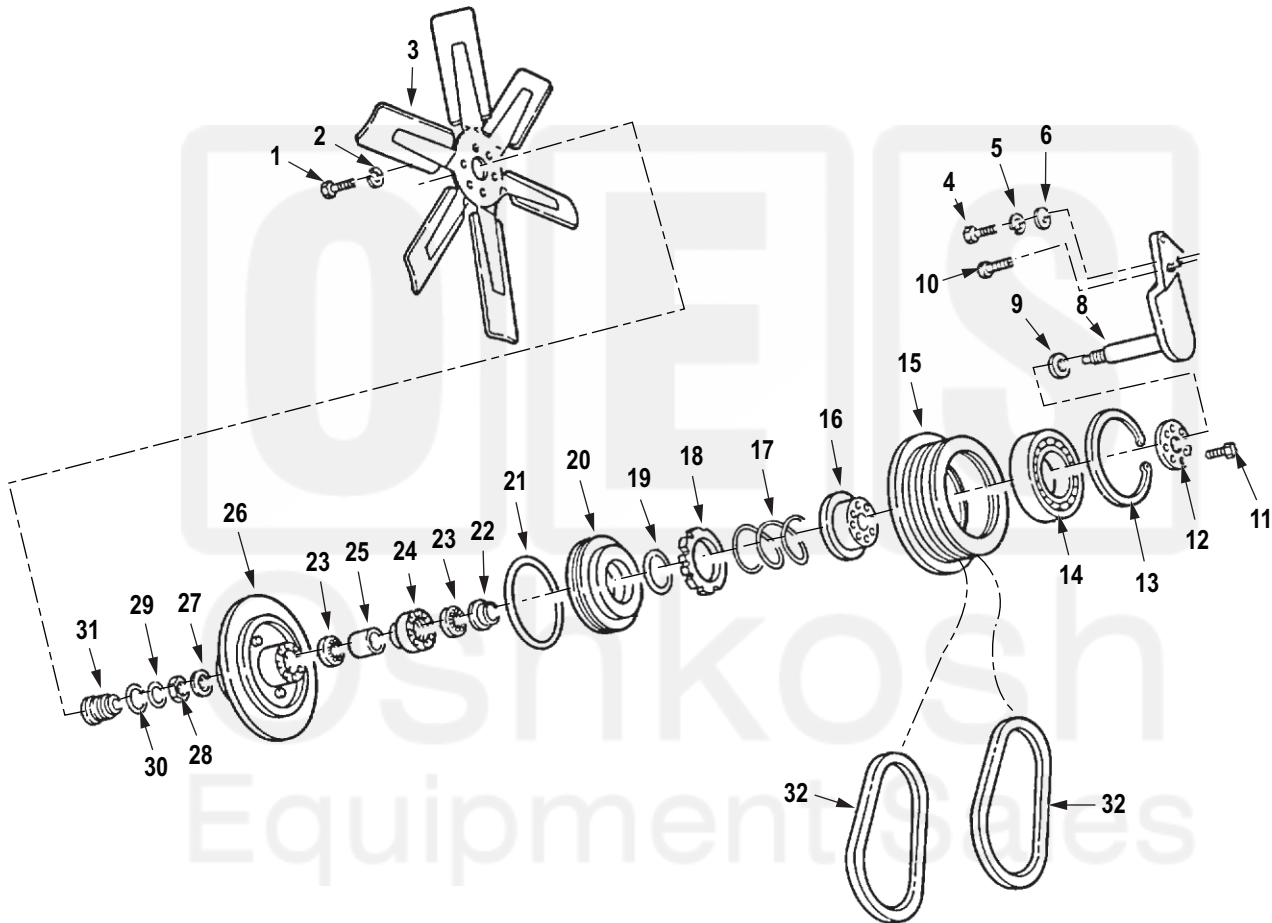

R0120DAA

Figure 120. Fan Clutch Assembly, Fan, and Belts (M939, M939A1).

(1) ITEM NO.	(2) SMR CODE	(3) NSN	(4) CAGEC	(5) PART NUMBER	(6) DESCRIPTION AND USABLE ON CODE (UOC)	(7) QTY
<b>GROUP 0505 FAN ASSEMBLY.</b>						
<b>FIG. 120. FAN CLUTCH ASSEMBLY, FAN, AND BELTS (M939, M939A1).</b>						
1	PAFZZ	5305-01-210-4595	97403	13222E0109	SCREW,ROLLER ASSEMB UOC: DAC,DAD,DAE,DAF,DAG,DA H,DAJ,DAL,DAW,DAX,V14,V15,V16, V17,V18,V19,V20,V21,V22,V24 .....	6
2	PAFZZ	5310-00-637-9541	00198	132661	WASHER,LOCK UOC: DAC,DAD,DAE,DAF,DAG,DA H,DAJ,DAL,DAW,DAX,V14,V15,V16, V17,V18,V19,V20,V21,V22,V24 .....	6
3	PAFZZ	4140-01-089-3058	61125	460516	IMPELLER,FAN,AXIAL RIGHT HAND SUCKER UOC: DAC,DAD,DAE,DAF,DAG,DA H,DAJ,DAL,DAW,DAX,V14,V15,V16, V17,V18,V19,V20,V21,V22,V24 .....	1
4	PAFZZ	5305-00-719-5235	80204	B1821BH050F175N	SCREW,CAP,HEXAGON H UOC: DAC,DAD,DAE,DAF,DAG,DA H,DAJ,DAL,DAW,DAX,V14,V15,V16, V17,V18,V19,V20,V21,V22,V24 .....	3
5	PAFZZ	5310-00-003-4094	80205	MS35338-48	WASHER,LOCK UOC: DAC,DAD,DAE,DAF,DAG,DA H,DAJ,DAL,DAW,DAX,V14,V15,V16, V17,V18,V19,V20,V21,V22,V24 .....	3
6	PAFZZ	5310-01-121-1703	24617	2436165	WASHER,FLAT UOC: DAC,DAD,DAE,DAF,DAG,DA H,DAJ,DAL,DAW,DAX,V14,V15,V16, V17,V18,V19,V20,V21,V22,V24 .....	2
7	PAFHH	2520-01-115-2285	21102	FC212000	CLUTCH ASSEMBLY,FRI ENGINE COOLING UOC: DAC,DAD,DAE,DAF,DAG,DA H,DAJ,DAL,DAW,DAX,V14,V15,V16, V17,V18,V19,V20,V21,V22,V24 .....	1
8	PBHZZ	3020-01-124-6079	21102	FC200007	. BRACKET AND SHAFT A UOC: DAC,DAD,DAE,DAF,DAG,DA H,DAJ,DAL,DAW,DAX,V14,V15,V16, V17,V18,V19,V20,V21,V22,V24 .....	1
9	PAHZZ	5365-01-126-5192	21102	FC030002	. SPACER,RING UOC: DAC,DAD,DAE,DAF,DAG,DA H,DAJ,DAL,DAW,DAX,V14,V15,V16, V17,V18,V19,V20,V21,V22,V24 .....	1
10	PAHZZ	5305-01-161-6000	21102	FC200010	. SCREW,CAP,HEXAGON H UOC: DAC,DAD,DAE,DAF,DAG,DA H,DAJ,DAL,DAW,DAX,V14,V15,V16, V17,V18,V19,V20,V21,V22,V24 .....	2